

INTERLOCAL COOPERATION AGREEMENT
between
SALT LAKE COUNTY
and
THE CITY OF COTTONWOOD HEIGHTS

This Agreement between **SALT LAKE COUNTY**, a body corporate and politic of the State of Utah ("County") and **THE CITY OF COTTONWOOD HEIGHTS**, a municipal corporation of the State of Utah ("City"). The County and the City may each be referred to herein as a "Party" and collectively as the "Parties."

RECITALS:

A. County has entered into a restated interlocal agreement to lease 1.95 acres property at a "Park and Ride" lot at approximately 7000 South Wasatch Boulevard in Cottonwood Heights, Utah;

B. Salt Lake County has purchased a bicycle repair station with funds allocated to the Salt Lake County Bicycle Advisory Committee to be installed and maintained at the "Park and Ride" lot for the benefit and use of Salt Lake County residents;

C. The City of Cottonwood Heights will install and maintain the bicycle repair station at the "Park and Ride" lot consistent with the terms of this Agreement.

AGREEMENT:

NOW THEREFORE, in consideration of the mutual promises contained in this Agreement, the Parties hereby agree as follows:

Scope of Work.

1.1 County agrees to turn over the bicycle repair station it has purchased to the City for installation at the Park and Ride lot located at approximately 7000 South Wasatch Boulevard in Cottonwood Heights, Utah.

1.2 City agrees to install the bicycle repair station at the Park and Ride lot according to the manufacturer's instructions (Exhibit A), which are attached hereto and incorporated by reference, for use by the general public to repair and maintain bicycles along the route adjacent to the Park and Ride lot.

1.3 City agrees to maintain the Park and Ride lot consistent with the manufacturer's instructions and to replace any parts due to regular wear and tear, vandalism, or any other

damage as needed. The City agrees to maintain the repair station for the duration of this Agreement.

General Provisions.

2.1. Binding Agreement. This Agreement shall be binding upon and shall inure to the benefit of the successors and assigns of the respective parties hereto.

2.2. Captions. The headings used in this Agreement are inserted for reference purposes only and shall not be deemed to define, limit, extend, describe, or affect in any way the meaning, scope or interpretation of any of the terms or provisions of this Agreement or the intent hereof.

2.3. Counterparts. This Agreement may be signed in any number of counterparts with the same effect as if the signatures upon any counterpart were upon the same instrument. All signed counterparts shall be deemed to be one original.

2.4. Severability. The provisions of this Agreement are severable, and should any provision hereof be void, voidable, unenforceable or invalid, such void, voidable, unenforceable, or invalid provision shall not affect the other provisions of this Agreement.

2.5. Waiver of Breach. Any waiver by either party of any breach of any kind or character whatsoever by the other, whether such be direct or implied, shall not be construed as a continuing waiver of or consent to any subsequent breach of this Agreement.

2.6. Cumulative Remedies. The rights and remedies of the parties hereto shall be construed cumulatively, and none of such rights and remedies shall be exclusive of, or in lieu or limitation of, any other right, remedy, or priority allowed by law.

2.7. Amendment. This Agreement may not be modified except by an instrument in writing signed by the parties hereto.

2.8. Time of Essence. Time is the essence in this Agreement.

2.9. Interpretation. This Agreement shall be interpreted, construed, and enforced according to the substantive laws of the state of Utah.

2.10. Notice. Any notice or other communication required or permitted to be given hereunder shall be deemed to have been received (a) upon personal delivery or actual receipt thereof or (b) within three (3) days after such notice is deposited in the United States mail, certified mail postage prepaid and addressed to the parties at their respective addresses.

2.11. Exhibits and Recitals. The Recitals set forth above and all exhibits to this Agreement are incorporated herein to the same extent as if such items were set forth herein in their entirety within the body of this Agreement.

2.12. Governmental Immunity. Both parties are governmental entities under the Governmental Immunity Act, UTAH CODE ANN. § 63G-7-101, *et seq.* (the “*Immunity Act*”). Consistent with the terms of the Immunity Act, the parties agree that each party is responsible and liable for any wrongful or negligent acts which it commits or which are committed by its agents, officials, or employees. Neither party waives any defenses or limits of liability otherwise available under the Immunity Act and all other applicable laws, and both parties maintain all privileges, immunities, and other rights granted by the Immunity Act and all other applicable law.

2.13 Termination. Either Party may terminate the Agreement for any or no reason upon twelve (12) months written notice to the other Party.

2.14. Ethical Standards. The parties hereto represent that they have not: (a) provided an illegal gift or payoff to any officer or employee, or former officer or employee, or to any relative or business entity of an officer or employee, or relative or business entity of a former officer or employee of the other party hereto; (b) retained any person to solicit or secure this Agreement upon any contract, agreement or understanding for a commission, percentage, brokerage or contingent fee, other than bona fide employees of bona fide commercial agencies established for the purpose of securing business; (c) breached any of the ethical standards set forth in State statute or County’s Ethics, Gifts and Honoraria ordinance (Chapter 2.07, SALT LAKE COUNTY CODE OF ORDINANCES [2001]); or (d) knowingly influenced, and hereby promise that they will not knowingly influence, any officer or employee or former officer or employee to breach any of the ethical standards set forth in State statute or County ordinances.

2.15 Term. The term of this Agreement shall begin as of the date of execution and continue for a period of twenty years or upon termination by either party.

[Signature Page to Follow]

IN WITNESS WHEREOF, the Parties execute this Agreement on the dates shown below.

INTERLOCAL AGREEMENT - SIGNATURE PAGE FOR THE COUNTY

SALT LAKE COUNTY

By _____

Dated: _____, 20____

Reviewed by:

REGIONAL TRANSPORTATION
AND PLANNING

By _____

Ryan Perry
Director

Dated: _____, 20____

Approved as to Form and Legality:

/s/ Jason S. Rose, 26 March 2020
Senior Attorney

INTERLOCAL AGREEMENT – SIGNATURE PAGE FOR CITY

CITY OF COTTONWOOD HEIGHTS

By _____

Name: _____

Title: _____

Dated: _____, 20____

Attest:

_____, City Recorder

Date signed: _____

Approved as to Form and Legality:

CITY ATTORNEY

By _____

Name: _____

Dated: _____, 20____

Exhibit A

(Bicycle Repair Station -- Manufacturer's Instructions)

FIXIT Setbacks

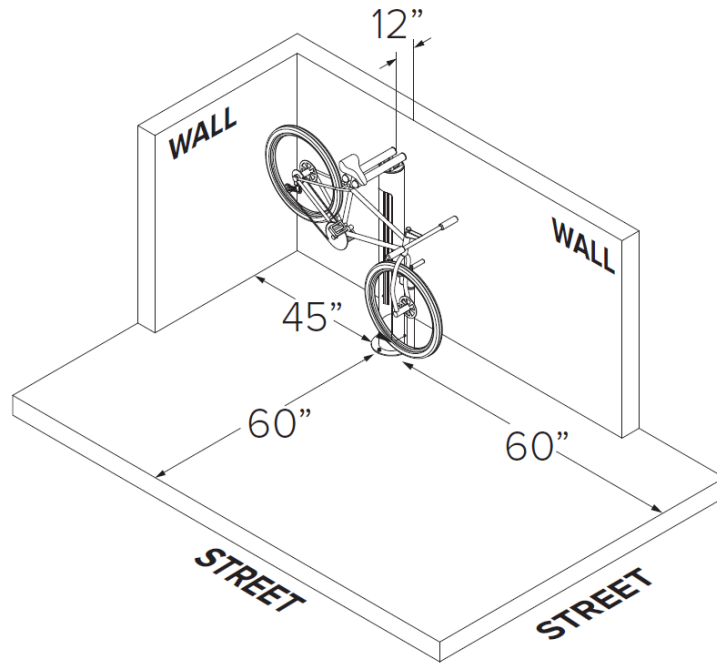

An optional wheel catch is available to hold bikes with no kick stands

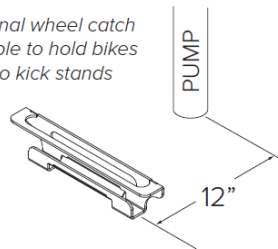

www.dero.com | 1-888-337-6729

© 2018 Dero

FIXIT Installation Instructions

TOOLS NEEDED

Hammer drill
3/8" masonry bit
Hammer
Socket Wrench
9/16" socket
1/2" socket
Tamper-proof socket (included)*
Socket extension, 6" min.

RECOMMENDED BASE MATERIAL

Solid concrete is the best base material for installation. To ensure the proper anchors are shipped with your rack, ask your Dero Rack representative which anchor is appropriate for your application. Be sure nothing is underneath the base material that could be damaged by drilling.



Be sure to save your tamper-resistant tools for any future maintenance. They are costly to replace.

1

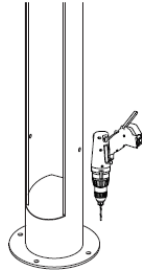

Reference the Fixit setback recommendations and place the upright in the desired location. Use the base as a template and drill (4) 3/8" x 3" holes in the concrete with a hammer drill and masonry bit. Clean up all concrete dust from drilling.

2

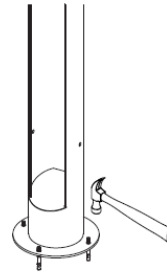

Hammer in the (4) wedge anchors. Leave at least 3/4" of an inch of exposed threads above the Fixit base.

3

Ⓣ = Tamper-proof Nuts
Ⓢ = Standard Nuts

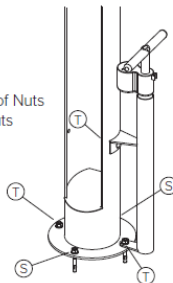

Decide which position the pump will be installed in and place the bottom pump flange over the corresponding wedge anchor. Attach the top pump flange to the Fixit upright with a carriage bolt, washer, and tamper-proof nut. Tighten all wedge anchors with washers and nuts.

Reserve one of the tamper-proof nuts to secure the tools.

4



Insert the tool cables into the cable slot on the Fixit upright.



DERO
A PLAYCORE Company

www.dero.com | 1-888-337-6729

© 2018 Dero

FIXIT Installation Instructions

5

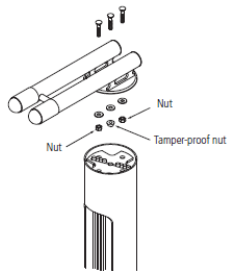

Place the bike hanger in the desired position on top of the Fixit upright and attach with carriage bolts, washers and nuts. **Apply the tamper-proof nut to center bolt to secure tools.**

If you would like us to add your station to our online map, email the station's geocoordinates to web@dero.com. These coordinates can be obtained by simply clicking a point on a Google Map.

<http://www.dero.com/fixitmap/fixitmap.html>

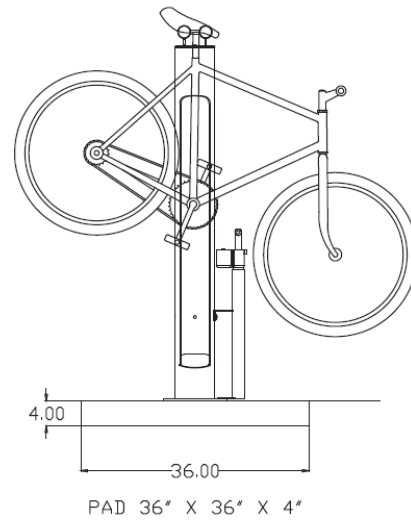
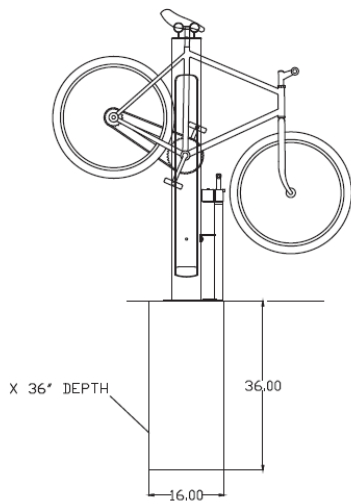

Pad recommendations for pouring along trail



www.dero.com | 1-888-337-6729

© 2018 Dero

FIXIT

Maintenance and Replacement

NOTE:

All threads for all parts of the pump are right-hand threads. They tighten clockwise, and loosen counter-clockwise ("righty tighty, lefty loosey"). However, when you are looking top-down at a bolt that threads from underneath, if you move it counter-clockwise from your point of view, you are actually tightening, not loosening, the nut! This has led to some unnecessary breakage of pump parts. Be sure you are looking at the nut with the proper orientation before tightening or loosening.

REMOVING THE AIR KIT FROM THE FIXIT

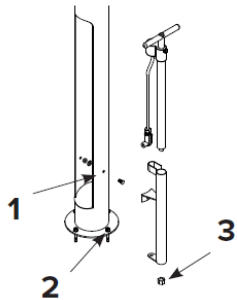

1. Remove nut and bolt on side of Fixit.
2. Remove tamperproof nut on bottom of Fixit, using the Tamperproof Penta Tool supplied for this purpose.
3. Once Airpump is removed, but still in sleeve, remove the 1 3/16" nut on the bottom of the sleeve (turning counter-clockwise). You can now slide the pump out.

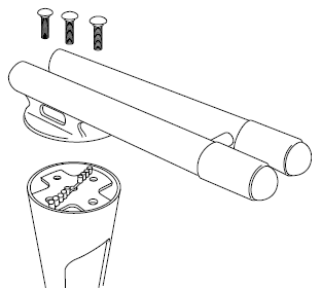

REPLACING TOOLS

There are three bolts at the top of the Fixit. Underneath are two 3/8" nuts, and one penta tamper-proof nut (center bolt). These are all best removed with a socket wrench, using the extension tool to enable you to reach the nuts. Once the nuts are removed, take off the cap to replace tools.

CHANGING THE PUMPHEAD

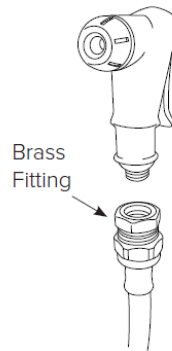

Remove the shrinkwrap. Unscrew the pumphead from the brass fitting (turning counter-clockwise). You will need to keep the brass fitting for the new pumphead. Replace the pumphead. If you want to put on shrinkwrap, then put the shrinkwrap sleeve over the hose before replacing pumphead. Once pumphead is on, pull shrinkwrap sleeve over the brass fitting and use a heatgun to shrink it.

CHANGING METAL HEAD™

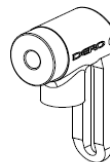

Remove Metal Head™ by turning counter-clockwise. You will need a 3/4" wrench. Replace with new Metal Head and tighten.



If you are replacing a plastic pump head with a Metal Head, you will need to also purchase a replacement hose.



DERO
A PLAYCORE Company

www.dero.com | 1-888-337-6729

© 2018 Dero